

DMAE Dosing Furnace

insertec
Hornos y Refractarios

Dosing furnace DMAE - En

The **DMAE** is an Aluminium Dosing Furnace without crucible, with electrical heating and electro-pneumatic dose system.

This furnace is valid to dose liquid aluminium on several aluminium casting processes such as Die Casting and Gravity.

The furnace is very good thermal isolated and has been designed to work under pressure up to 150 mbar..

The lining is made of monolithic refractory cement special to liquid aluminium contact..

The filling system is with liquid aluminium. And it can be done while working

The furnace include an elevator and tilting hydraulic table to reach the dose point and to

DMAE dosing furnaces work in automatic mode with the next characteristics::

- Constant pressure dosing system.
- The aluminium level is continuously measured and indicated by a five lamps indicator
- PLC control and 10" colour touch screen
- Temperature control by two thermocouples.

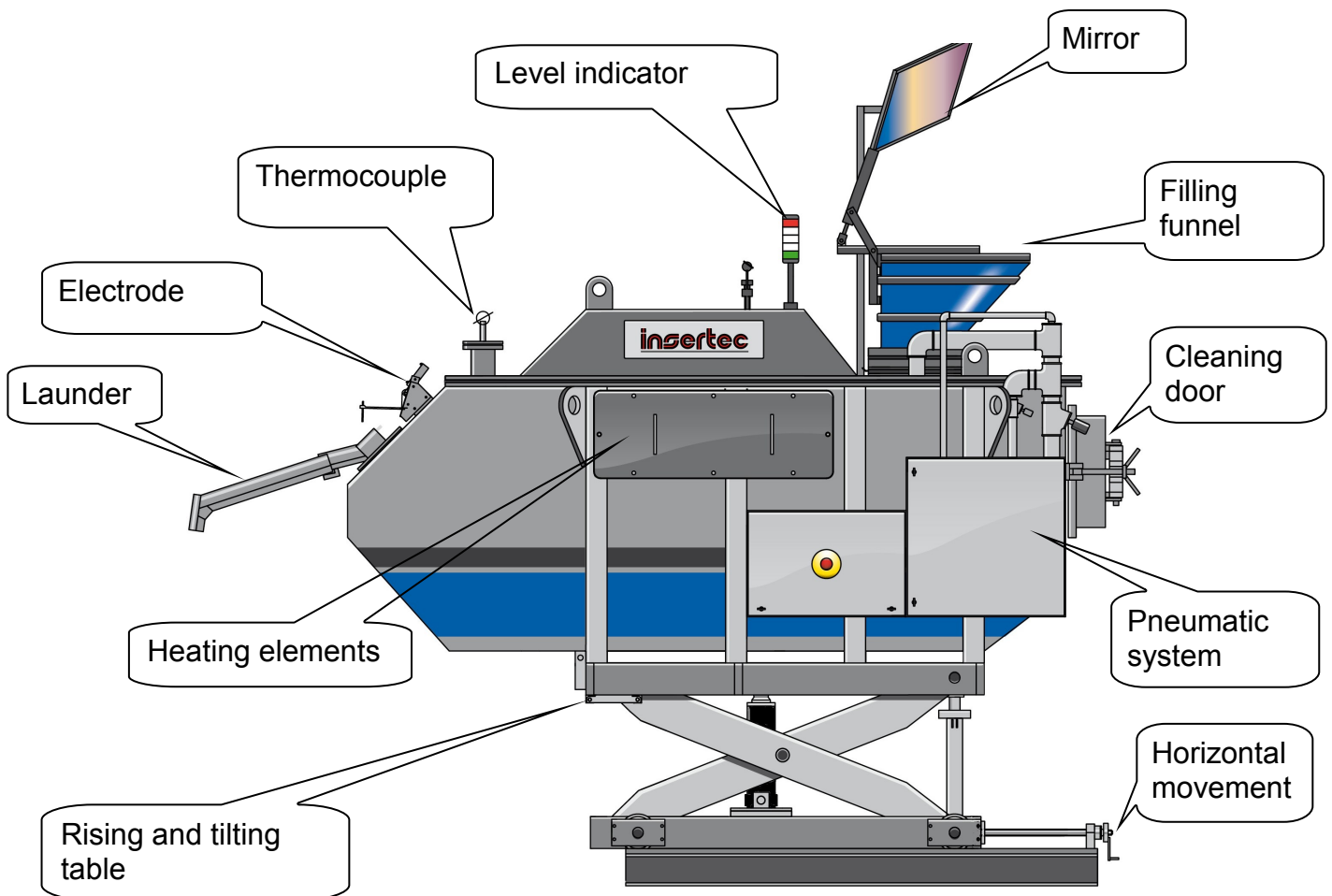

Ingeniería y Servicios Técnicos, S.A.

Hornos y Refractarios

FEATURES

- Enable to fill during automatic work
- Dose weight adjustable from the touch screen.
- Standard spare parts
- Very easy to calibrate.
- Height and horizontal movements.
- Cleaning door also available to empty..
- Interface by cable or Profibus..
- Dose from 0,3 to 100 Kg.
- Accuracy $\pm 1,5\%$
- Low power consumption

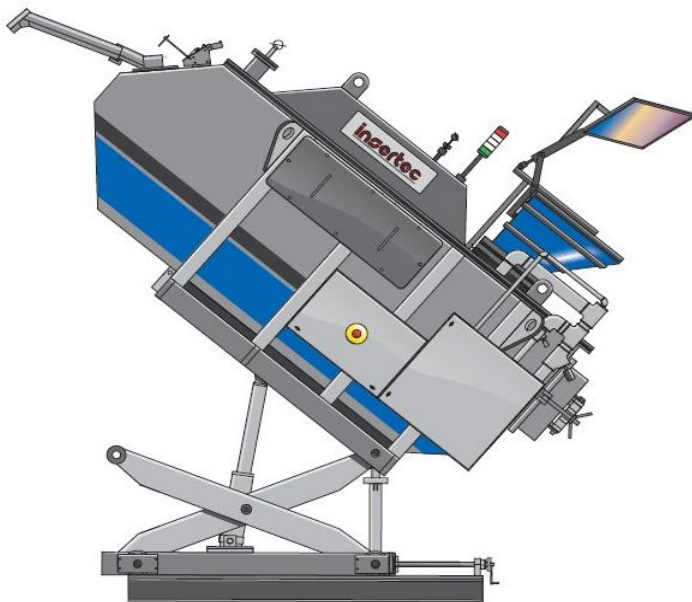
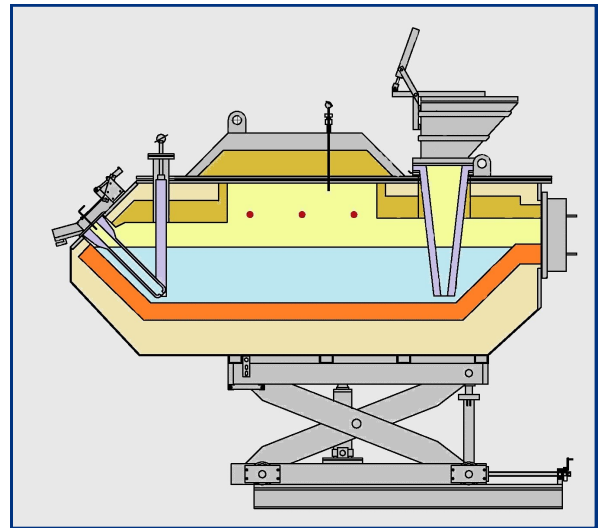

TECHNICAL CHARACTERISTICS

Model	Total capacity kg Al	Work Capacity kg Al	Dosing Weight Kg.	Power kW	Main dimensions			Weight kg
					Width	length	height	
DMAE-18-650	650	500	0,1 – 2	18	1980	2690	2820	3320
DMAE-21-900	900	700	1 – 4	21	2050	3040	2820	3470
DMAE-24-1200	1200	900	3 – 6	24	2200	3140	2920	3870
DMAE-30-1700	1700	1400	5 – 8	30	2350	3200	3290	6450
DMAE-35-2300	2300	1800	6 – 10	35	2485	3650	3320	7250
DMAE-35-3100	3100	2450	8 – 120	35	2690	3890	3330	9600

Ingeniería y Servicios Técnicos S.A.

Avda. Cervantes, 6 – 48970 Basauri, Vizcaya, Spain • Tel.: +34-944 409 420 / Fax: +34-944 496 624

e-mail: insertec@insertec.biz / www.insertec.biz